

## INSERT MAKEUP

All loose inserts must be at least 5mm below the size of the publication, both in length and width but not smaller than the closed edge 120 x 105mm.

Single sheets (2pp) must be on paper no lighter than 90gsm.

It is not possible to machine insert a concertina folded insert – please contact the Production Department for further information.

All multiple fold inserts must have at least one “closed edge” for mechanical processing i.e: .at least one edge must be formed by a fold.

This folded edge is the leading edge being fed into the publication

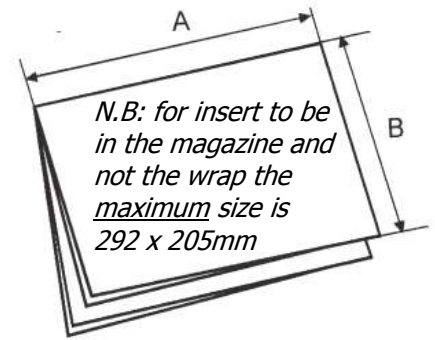

## DELIVERY & PRESENTATION

- 1.1 **DELIVERY TIMES** – is available 24/6 – from 8am on Sunday until 8am on Saturday.
- 1.2 **DELIVERY NOTES** - Every pallet should have a clear identification label and all deliveries of inserts, etc. must be accompanied by a delivery note which clearly states:
  - a. Title of the publication in which the insert is to be used.
  - b. The publication date and/or issue.
  - c. Customers name
  - d. Title of the insert
  - e. The quantity of inserts delivered per box/per package & total number of pallets and/or boxes supplied.
    - Inserts that are to be used for different issues/publications should be supplied on separate pallets, and appropriate quantities stated on the delivery notes.

We are unable to inspect and count incoming quantities and consequently cannot under any circumstances warrant these quantities. Failure to comply with the above criteria could result in inserts not being processed to the agreed time scale. ***Deliveries of inserts which are not accompanied by a delivery note may be rejected at the factory unless suitable information can be obtained at the time of delivery.***

- 1.3 **PRESENTATION ON DELIVERY** - Inserts that are not presented according to the following guidelines will not be accepted.

Inserts contained in a box/package below A5 size should be bound with elastic bands

Folded inserts presented in stacks should be turned through 180 degrees in suitable quantities but never turned upside down. Turning in quantities in less than 20 would make the production process very slow

If there are inserts outside the above parameters e.g. strange shapes, oddities and cut-outs, you are advised to contact the Production Department to discuss the requirements. We are able to process many awkward inserts provided we are informed in advance, including attaching cd's to covers, sachets or promotional items placed in certain areas of the magazine, banding and promotional equipment etc

***Inserts which are badly or incorrectly packed will be subject to an additional handling charge or rejected***

## DELIVERY ADDRESS

Please deliver according to the above specifications for the attention of **Mark Vincent** to:  
**Stephens and George Group, Goat Mill Road, Dowlais, Merthyr Tydfil, CF48 3TD, Wales**